

WALMAZ STAMPI is a reliable partner in designing and manufacturing hand-transfer, progressive and transfer dies for the cold cutting and forming of any kind of sheet metal.

Our company, which was founded in 1973, has been able to combine its initial handicraft skills with the efficiency of a technologically advanced company. Thanks to the modern 2D and 3D softwares and to Walmaz's long and ample experience, our designers study the tooling in collaboration with the customer and are constantly searching for innovative technical solutions. Customer satisfaction, a drive for longlasting business relationships and a constant commitment for improvement are the primary goals of the company.





WALMAZ STAMPI si propone come qualificato ed affidabile partner per la progettazione e la costruzione di stampi a blocco, a passo progressivo ed a transfer per la tranciatura e la deformazione a freddo di ogni tipo di lamiera.

Fondata nel 1973, l'azienda ha saputo associare le capacità artigianali proprie della fondazione all'efficienza di un'industria tecnologicamente all'avanguardia. Avvalendosi di moderni software di progettazione 2D e 3D e di una lunga e diversificata esperienza maturata nel corso degli anni, i progettisti sviluppano l'attrezzatura in stretta collaborazione con il cliente, nella costante ricerca di soluzioni tecniche innovative.

La soddisfazione del cliente, la ricerca di un rapporto duraturo di collaborazione ed il costante desiderio di miglioramento sono alla base di ogni scelta aziendale.

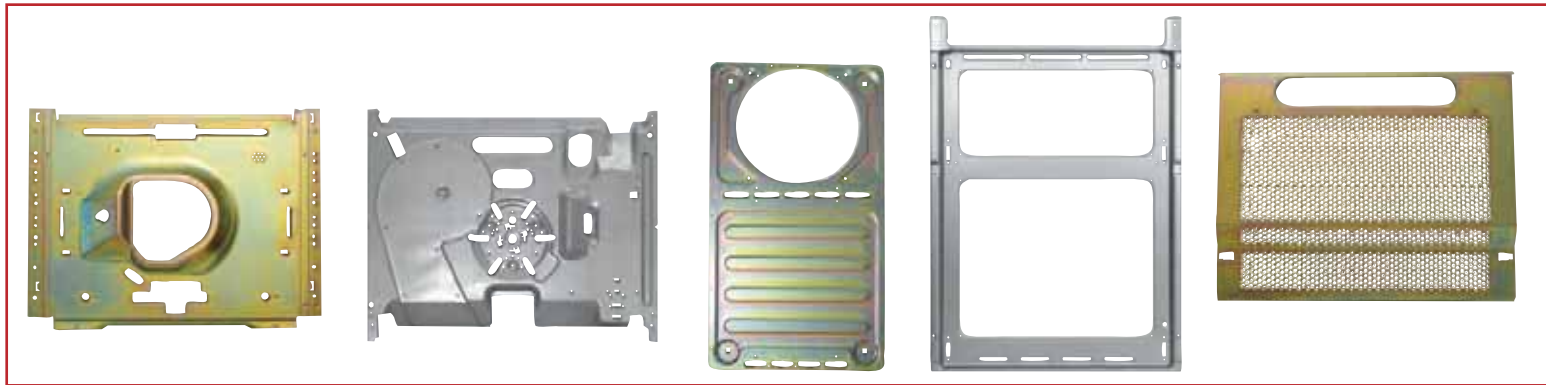
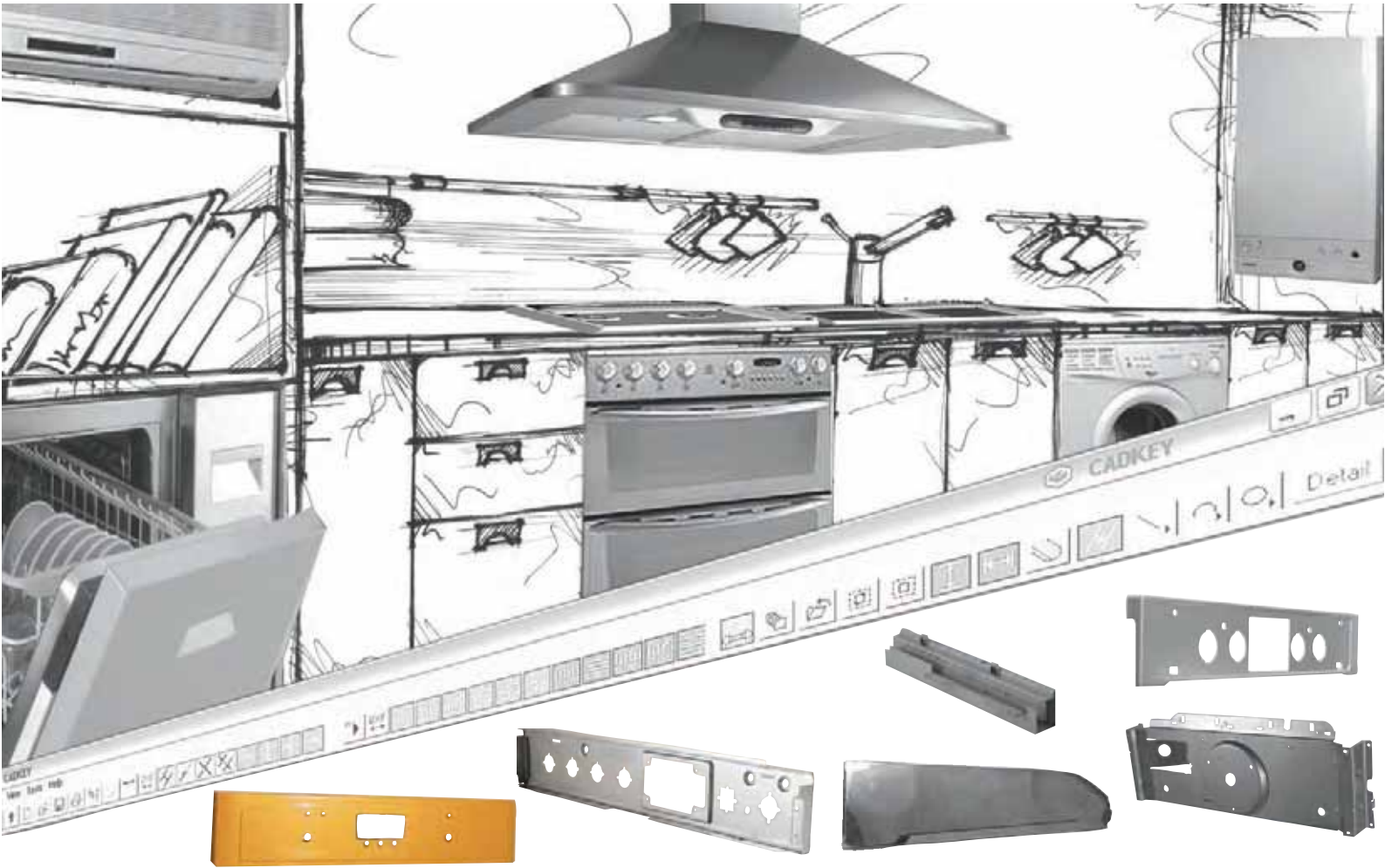



ELETTRODOMESTICO | HAUSHALTSGERÄTE | ELECTRODOMÉSTICO
HOUSEHOLD APPLIANCES

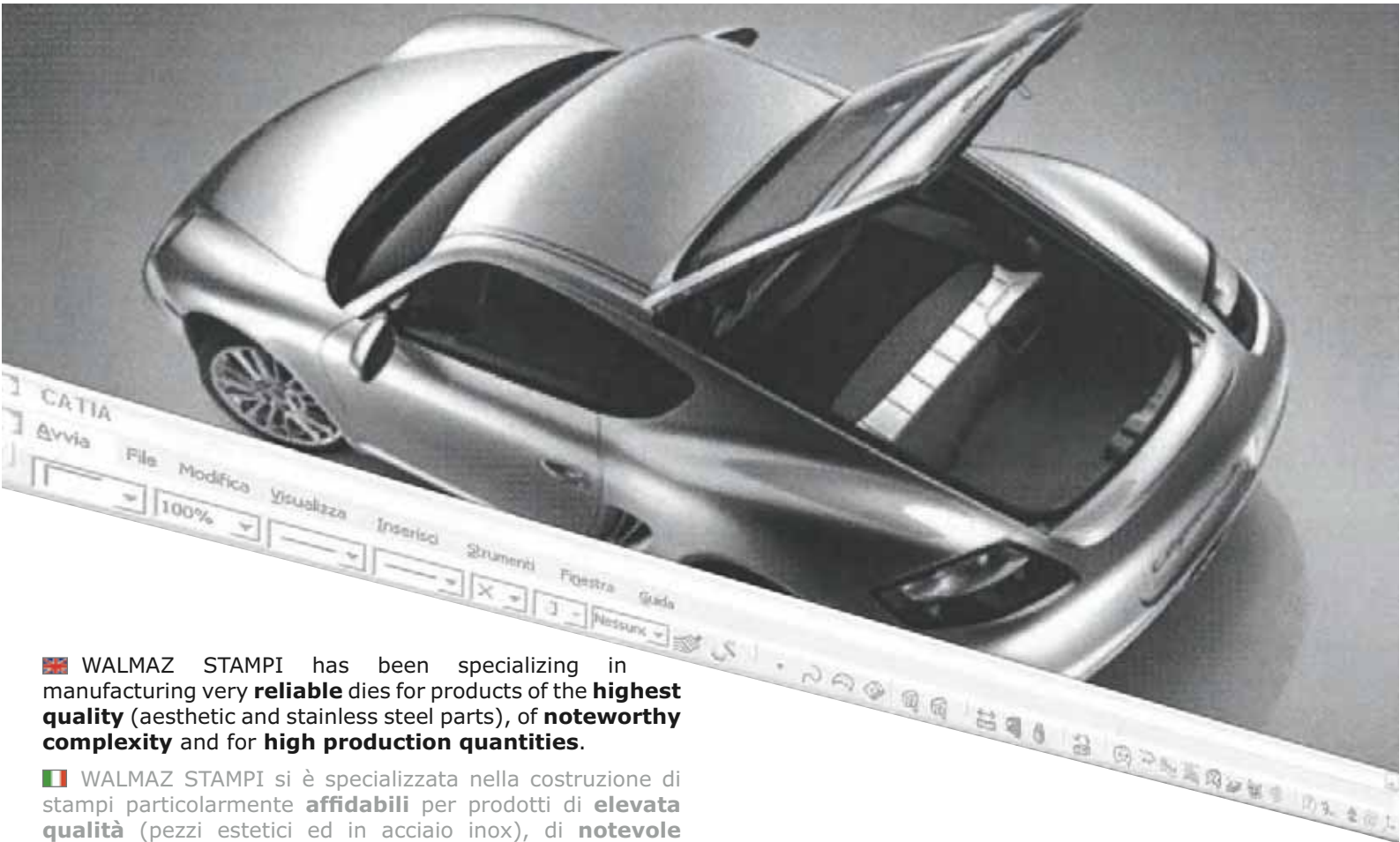

WALMAZ STAMPI has been specializing in manufacturing very **reliable** dies for products of the **highest quality** (aesthetic and stainless steel parts), of **noteworthy complexity** and for **high production quantities**.

WALMAZ STAMPI si è specializzata nella costruzione di stampi particolarmente **affidabili** per prodotti di **elevata qualità** (pezzi estetici ed in acciaio inox), di **notevole complessità** e con **alti quantitativi** di produzione.

WALMAZ STAMPI baut **qualitativ hochwertige, komplexe und zuverlässige** Werkzeuge.

WALMAZ STAMPI es especializada en la fabricación de troqueles particularmente **fiabiles** para productos de **alta calidad** (piezas estéticas y en acero inoxidable), de **notable complejidad** y con **altas cantidades** de producción.



CLIMATIZZAZIONE | KLIMAANLAGEN | CLIMATIZACIÓN **CLIMATE CONTROL**



AUTOMOBILISTICO | AUTOMOBILINDUSTRIE | AUTOMÓVIL **AUTOMOTIVE INDUSTRY**



ALTRI SETTORI | ANDERE BRANCHEN | OTROS SECTORES **OTHER SECTORS**



TRANSFER AND TANDEM DIES

STAMPI A TRANSFER E A BLOCCO | TRANSFER- UND EINLEGEWERKZEUGE
TROQUELES TRANSFER Y CONVENCIONALES

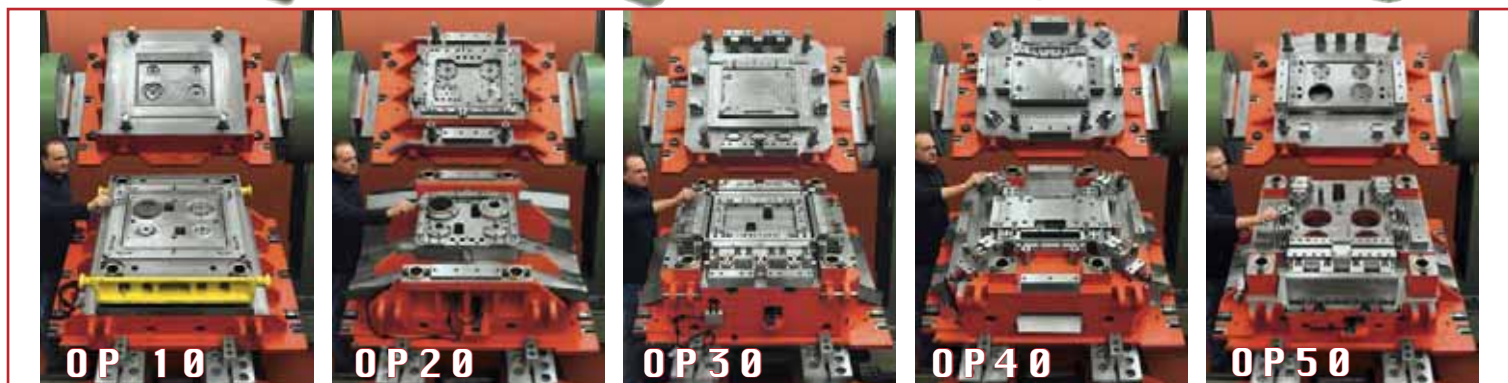
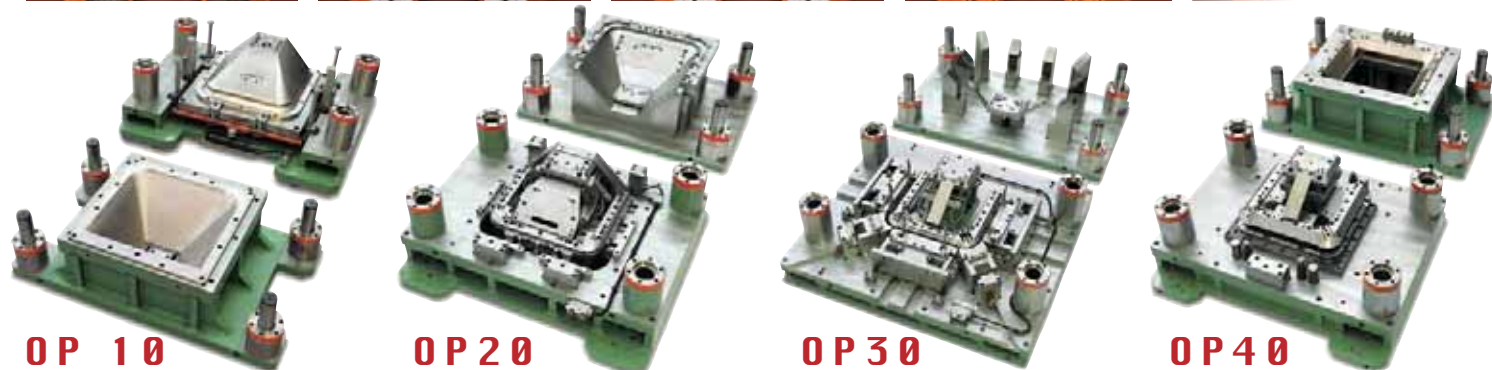
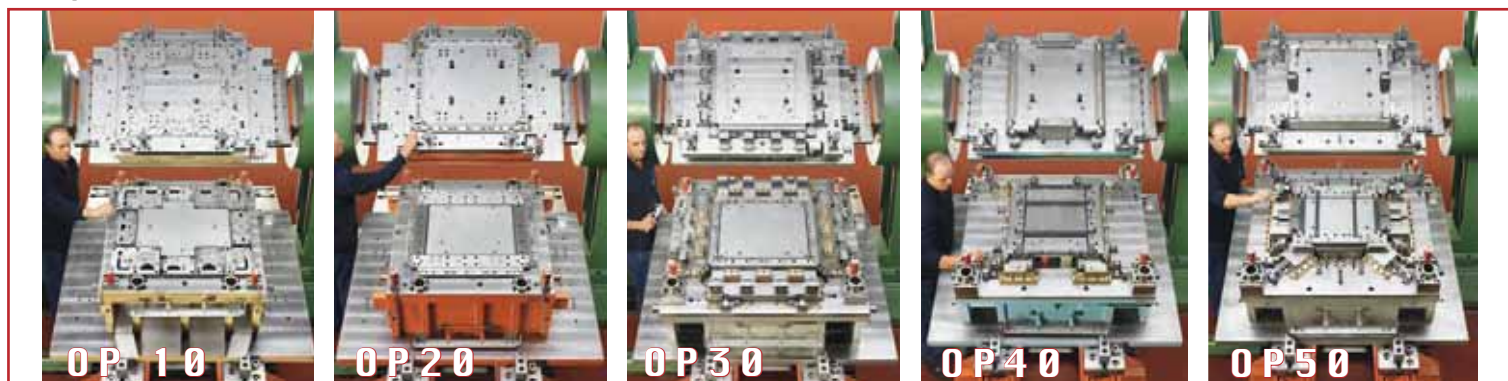

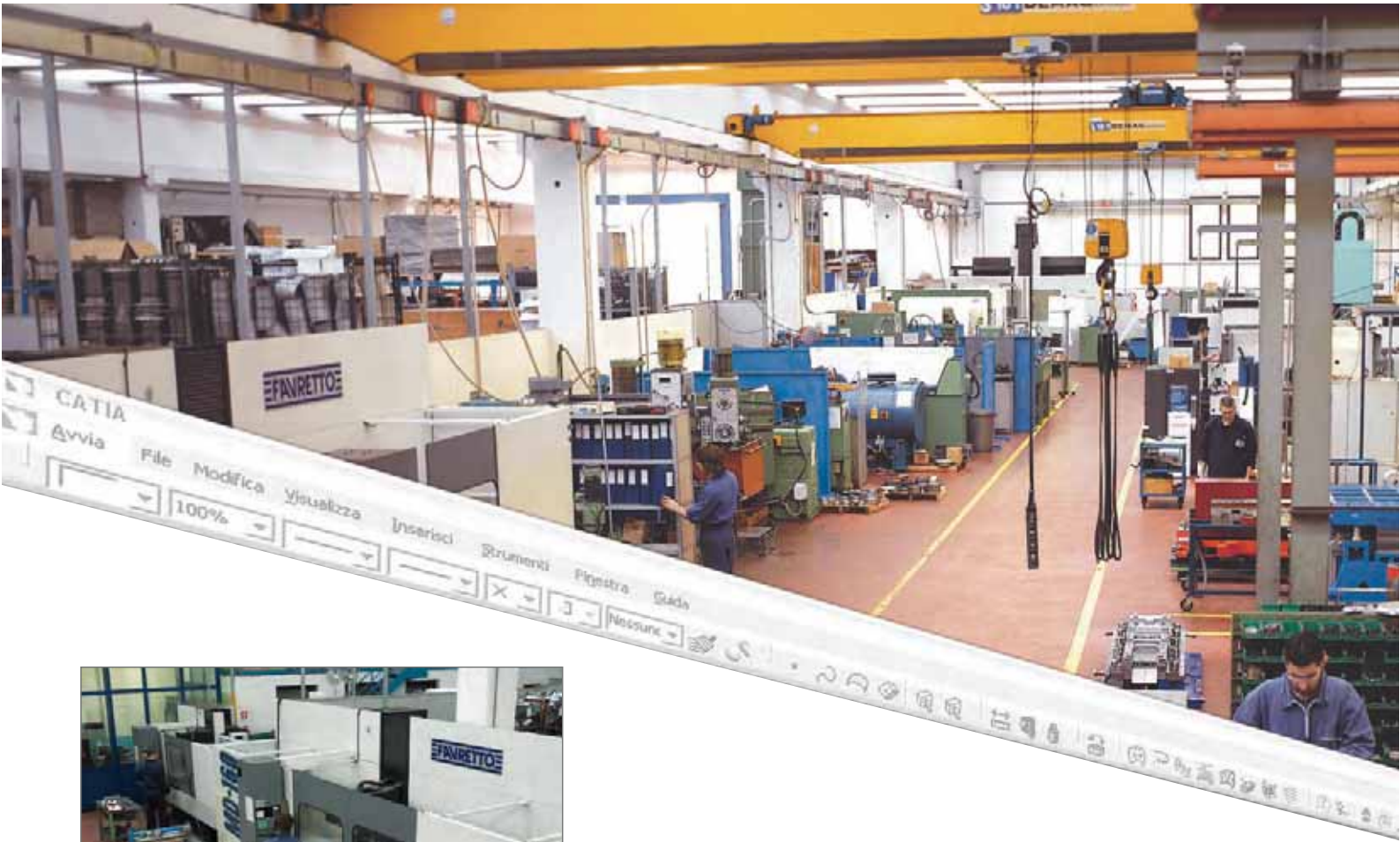

GRINDING MACHINES

RETTIFICHE | SCHLEIFMASCHINEN | RECTIFICADORAS

🇬🇧 The dies are made from certified best-quality materials, hardened and tempered at controlled hardness and, if required, PVD coated. The precision of the machining is guaranteed by the constant renewal of the mechanical equipment, provided with advanced numerical control systems and directly linked to the design department via DNC. All dies are tested with presses used specifically for this purpose and the samples are given to the customers together with the dimensional report performed by the 3D measuring machine. The archiving of the work programs coupled with the accuracy in the production of all items allow us to guarantee the **perfect interchange of spare parts**. The real passion for our activity means utmost reliability of the manufactured dies and highest quality of the final product.



CNC MILLING MACHINES

FRESATRICI CNC | CNC FRÄSEMACHINEN | FRESADORAS CNC

🇮🇹 Gli stampi vengono realizzati con materiali certificati della migliore qualità, temprati e rinvenuti a durezza controllata e, quando necessario, rivestiti superficialmente. La precisione delle lavorazioni è garantita dal continuo rinnovamento dei macchinari, tutti dotati di moderni sistemi di controllo numerico e collegati via cavo all'ufficio progettazione. I collaudi vengono eseguiti con presse dedicate ed i campioni ottenuti consegnati al cliente, accompagnati dal rilievo dimensionale eseguito con macchina di misura 3D. L'archiviazione dei programmi e l'accuratezza nella lavorazione dei componenti consentono di garantire la **perfetta intercambiabilità dei pezzi di ricambio**. La profonda passione per il nostro lavoro si traduce in massima affidabilità degli stampi costruiti ed elevata qualità del prodotto ottenuto.



HIGH SPEED MILLING MACHINES

FRESATRICI AD ALTA VELOCITÀ | SCHNELLAUFENDE FRÄSEMACHINEN | FRESADORAS DE ALTA VELOCIDAD



ELETTROEROSIONI | ERODIERMACHINEN | ELECTROEROSIÓN

 Die Werkzeuge werden aus zertifiziertem erstklassigen Material gefertigt, das zunächst gehärtet und wenn nötig beschichtet wird. Unsere innovative technische Ausstattung gewährleistet eine qualitativ hochwertige Bearbeitung. Die NC gesteuerten Bearbeitungszentren sind online mit der Konstruktionsabteilung verbunden. Alle von uns gefertigten Werkzeuge werden auf Stanzautomaten abgemustert und mit der 3D Messmaschine vermessen. Der Kunde erhält neben dem beauftragten Werkzeug die Musterteile und den Prüfbericht. Darüber hinaus garantieren wir, durch die **lückenlose Archivierung aller Bearbeitungsprogramme, eine reibungslose Ersatzteilversorgung.**

Die tiefe Leidenschaft für unsere Arbeit äußert sich in der maximalen Zuverlässigkeit der gebauten Werkzeuge und der hohen Qualität des erzielten Produktes.

MONTAGGIO | MONTAGE | MONTAJE

 Los troqueles son fabricados con materiales de la mejor calidad, templados y endurecidos con dureza controlada y, cuando es necesario, recubiertos superficialmente. La precisión de las elaboraciones es asegurada por la continua renovación de los equipamientos utilizados, todos ellos dotados de avanzados sistemas de control numérico y conectados por cable al departamento de diseño. Los troqueles son ensayados con una prensa específica para este uso y las piezas obtenidas se entregan al cliente acompañadas de la relación dimensional completa efectuada por máquina de medición 3D. El archivo de los programas de elaboración y la precisión de construcción de todos los detalles permiten garantizar la perfecta **intercambiabilidad de las piezas de recambio.**

La profunda pasión por nuestro trabajo se traduce en máxima fiabilidad de los troqueles fabricados y elevada calidad del producto obtenido.

COLLAUDO | ABNAHME | PRUEBA



EROSION - EDM



ASSEMBLY



TRY-OUT

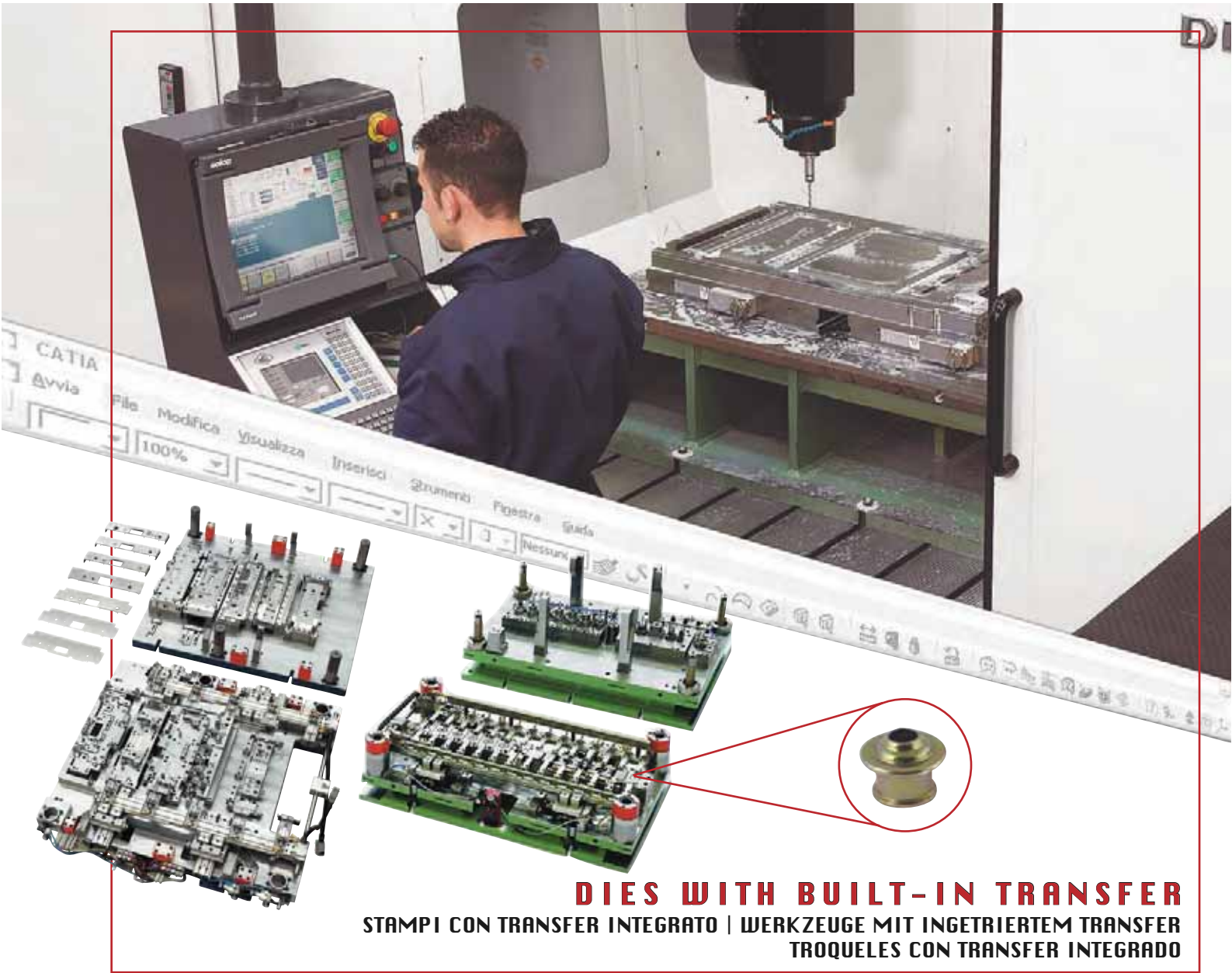

DIES WITH BUILT-IN TRANSFER
 STAMPI CON TRANSFER INTEGRATO | WERKZEUGE MIT INTEGRIERTEM TRANSFER
 TROQUELES CON TRANSFER INTEGRADO

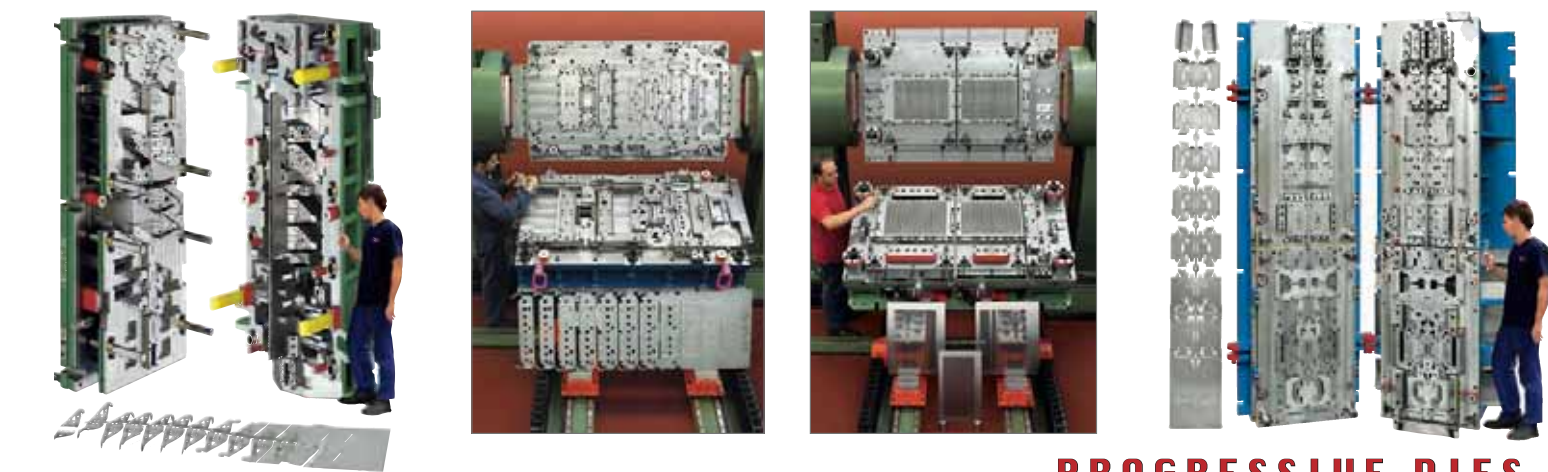

PROGRESSIVE DIES
 STAMPI A PASSO PROGRESSIVO | FOLGEVERBUNDWERKZEUGE | TROQUELES PROGRESSIVOS



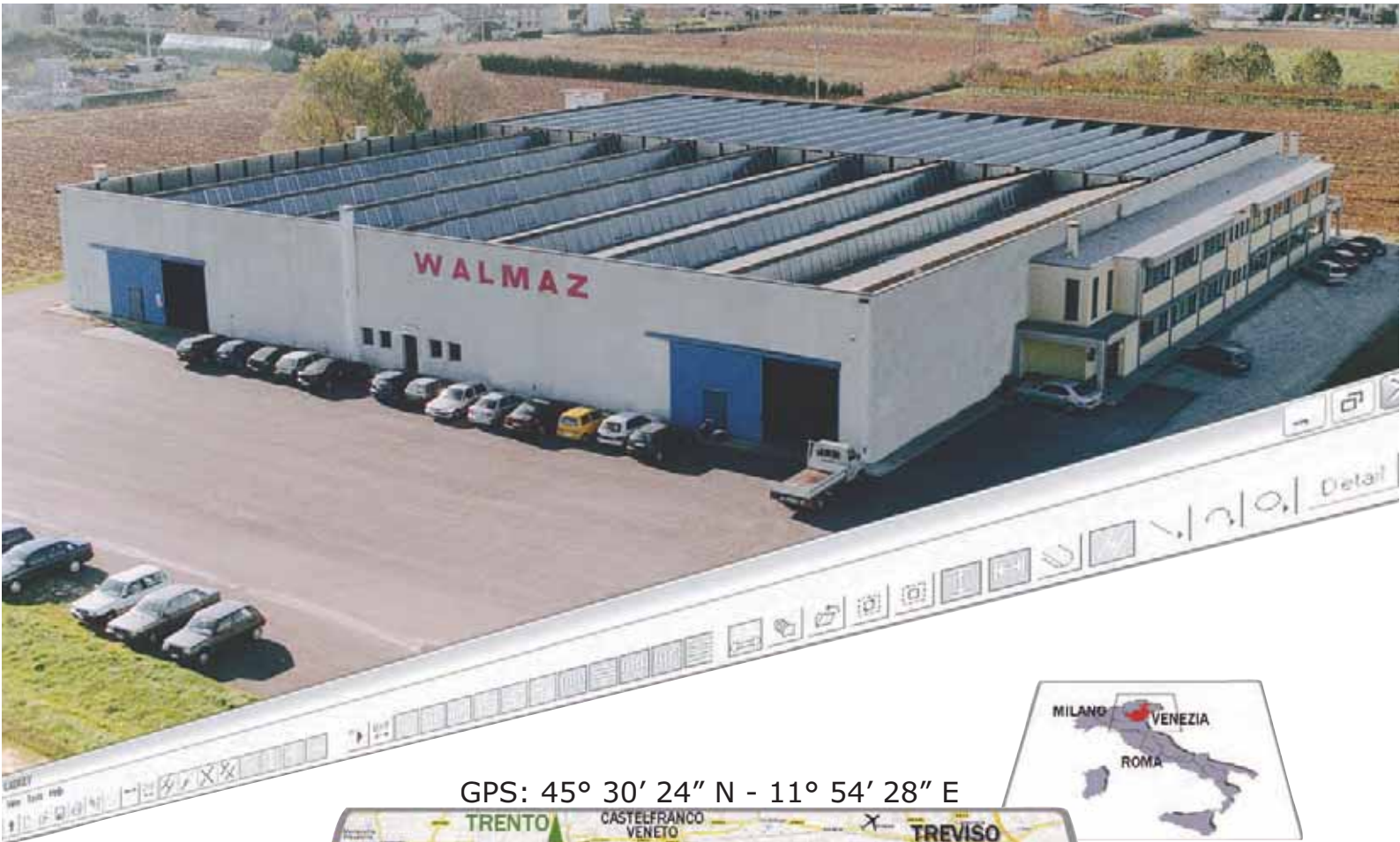

GPS: 45° 30' 24" N - 11° 54' 28" E



WALMAZ STAMPI srl
Via Rossignolo, 1/B - I 35011 CAMPODARSEGO (Padova) ITALY
Tel.+39 049 9200910 r.a. - Fax +39 049 5565907
www.walmaz.it - info@walmaz.it